

HISTORY of MICROELECTRONICS

Prof. C. Piguet
CSEM & EPFL, Switzerland

A replica of the point-contact transistor created by John Bardeen and Walter Brattain, under the supervision of William Shockley in 1947. Courtesy: Lucent.



Introduction to IC and History

- Vacuum tubes, discrete components
- 1947 The first integrated transistor (Bell Telephone Laboratories)
- 1959 The first bipolar planar transistor
- 1958 The first integrated circuit available as a monolithic chip (flip-flop)
- 1965 The first op-amp
- 1971 The first 4bit microprocessor (Intel 4004)
- 1972 The first 8bit microprocessor (Intel 8008)
- 1981 The first IBM PC

1947: Germanium Point Contact Transistor

The input current creates a P region (so PN) that modulates the output current

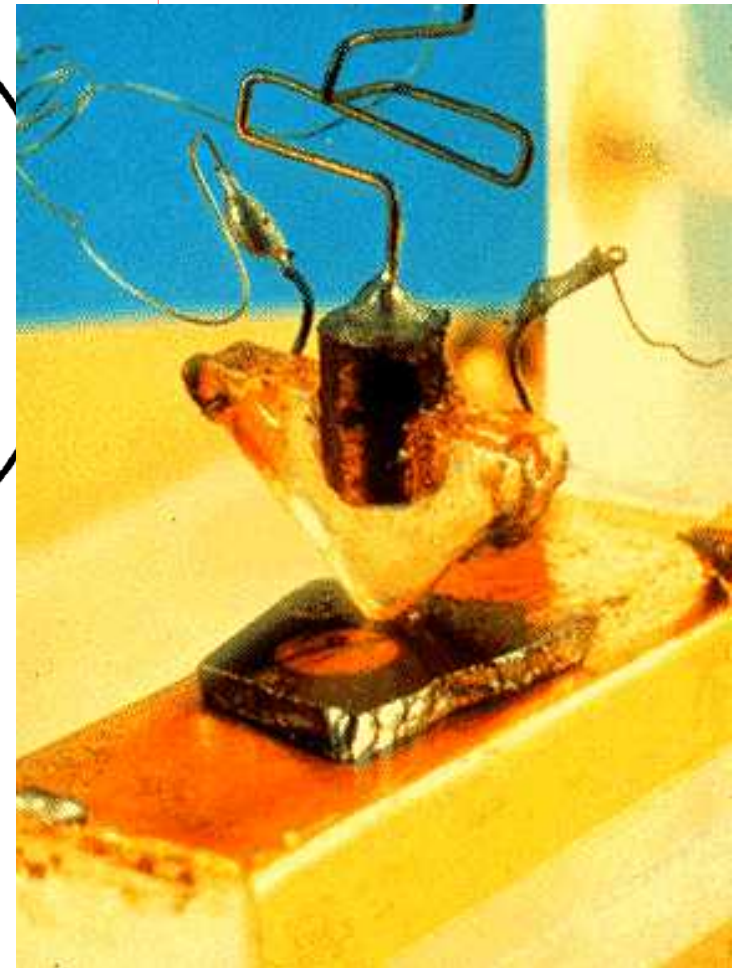
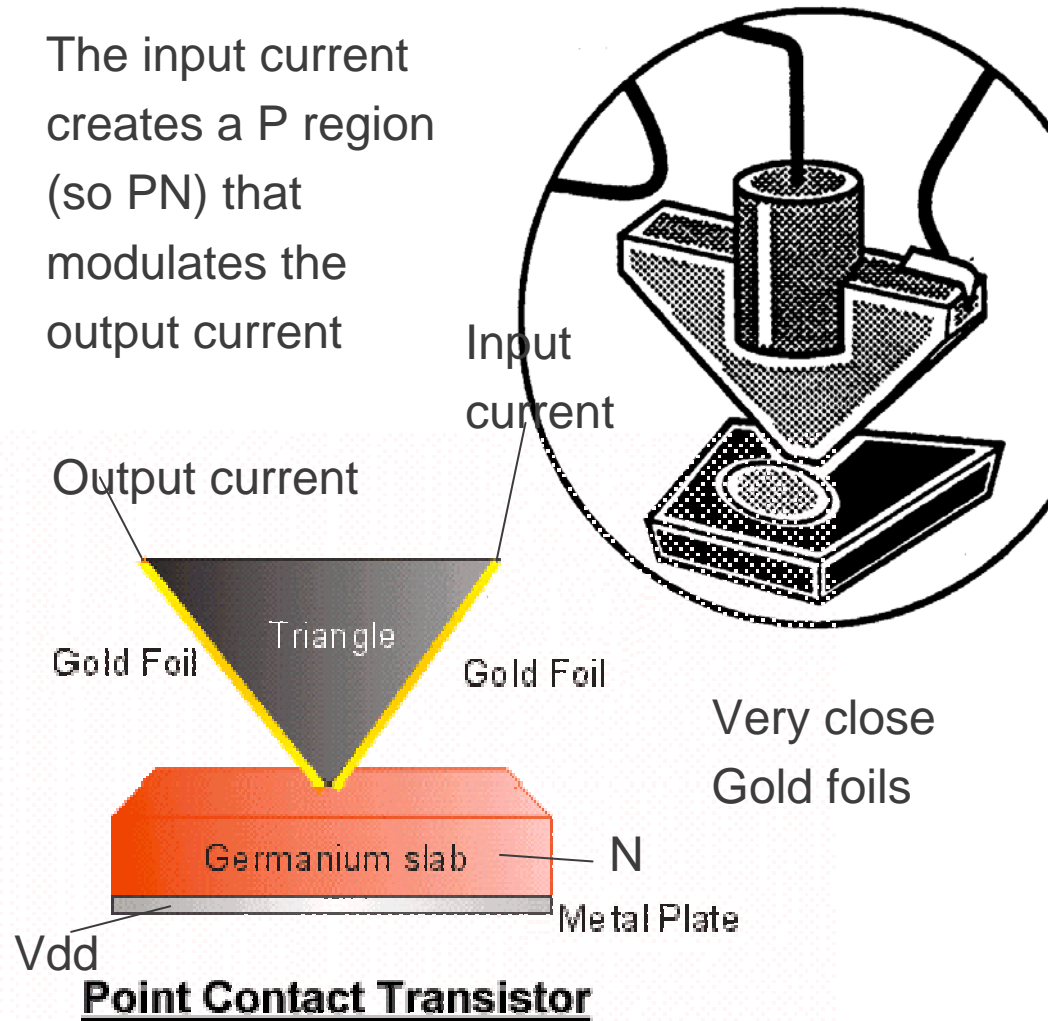

Transistor Invention

- on December 23, 1947 (point contact)
- on June 30, 1948, press was almost indifferent (bipolar)
- Inventors of the transistor are William Shockley, John Bardeen and Walter H. Brattain. They received the Nobel Prize in Physics in 1956
- Bell Laboratories licensed it freely and publicized it extensively in seminars and papers
- In 1935, a patent was issued to O. Heil for a field effect triode
- 1945: Bell Labs decided to limit their research to germanium and silicium, the simplest semiconductors

European Invention of the « Transistron »

- Strange and unknown story, reported in Spectrum November 2005, p. 46
- Transistron, very similar to the Bell Labs transistor, was invented at the end of WW II in Paris, by two German scientists Herbert Mataré and Heinrich Welker
- They worked at Westinghouse, Paris
- In 1948, a small radio used this « transistron » (May 14, 1948)

But French government and Westinghouse failed to capitalize on “transistron” (nuclear physics more important)

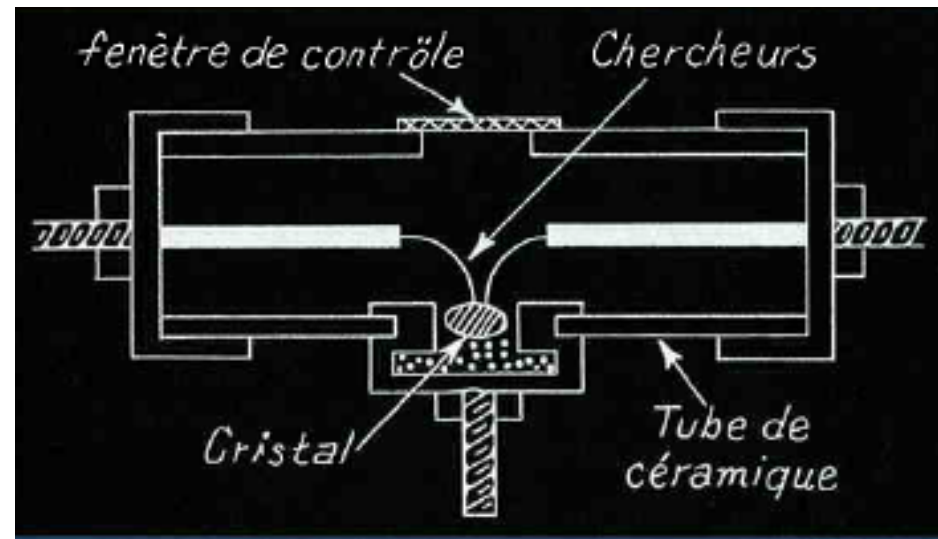

« Transistron »

- Two metal wires
- They contact germanium silver
- Another electrode
- It contacts the other face

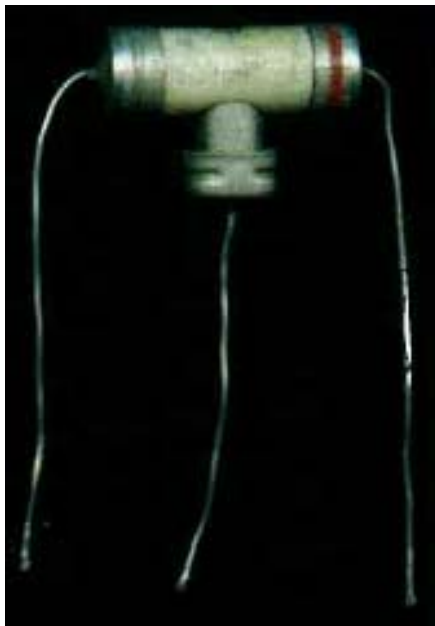

A voltage on this electrode influences the current through the others. It was a Transistor!

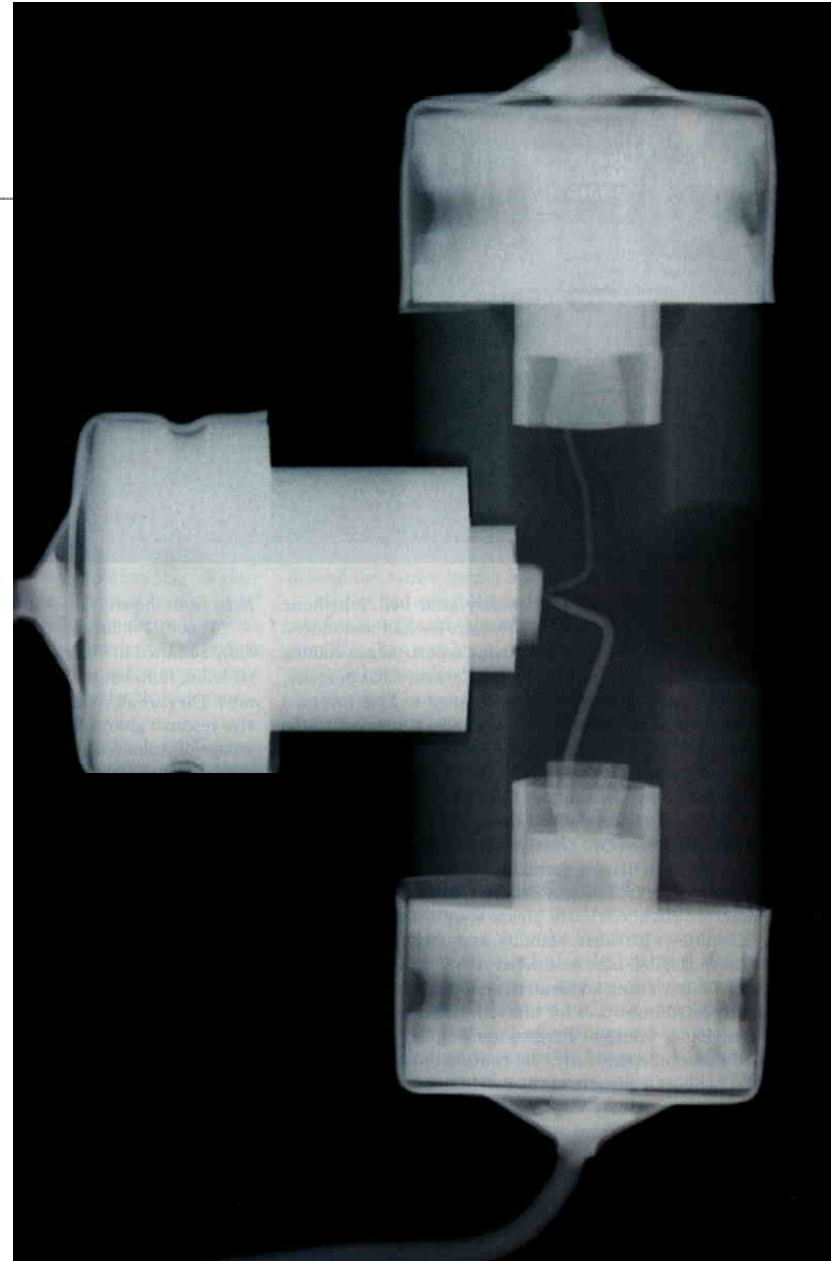

Germanium Bipolar Transistors and Tubes



On the right are submini tubes used in a Zenith Royal hearing aid
On the left are examples of CK718 junction germanium transistors produced by Raytheon and used in the Zenith Royal “T” hearing aid, with 252 representing week 52, 1952

Transistor Commercialization



- In 1958, the first field-effect transistor was working. It was called "Tecnitron" by its creator, S. Tszner, working in France.
- Engineers did not like transistors; they preferred tubes. The first market pull came from the hearing aids market, for which miniaturization was a must.
- Sonotone in February 1953; it contained 5 transistors
- In the mid-fifties, several companies were designing transistors - Raython, General Electric, Sylvania, RCA - and this was mass production
- Texas Instruments in 1953

The first commercially produced silicon transistor, developed by Texas Instruments in the early 1950s. Courtesy: Texas Instruments.

Germanium Bipolar Transistors

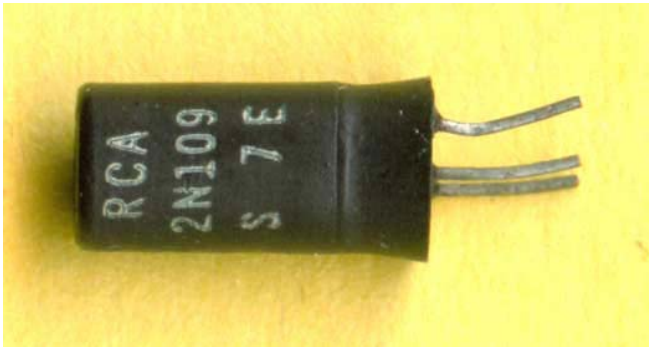

RCA introduced the 2N109 in 1955 (Germanium PNP Alloy Junction) as reliable germanium audio transistor and used in many transistorized radios. In 1956, the 2N109 cost a little over \$2.



CK722 is one of the best known transistors, introduced in early 1953 by Raytheon. The CK722 was the first mass produced germanium alloy junction transistor. Raytheon was the major manufacturer of hearing aid transistors.

Silicon Valley- Fairchild

- William Shockley, who left Bell Labs in 1954 to start its own company in Palo Alto, CA. --> Silicon Valley
- Young people, such as G. E. Moore and R. N. Noyce, joined Shockley Company
- Moore and Noyce, the "traitorous", as Shockley came to call them, set up in 1957 Fairchild
- Fairchild: in 1959 new planar technology
- Jack Kilby nor Robert Noyce conceived the integrated circuit in 1959
- "as the most significant development by Texas Instrument since ... the commercial silicon transistor"

Baby Computer of Manchester University

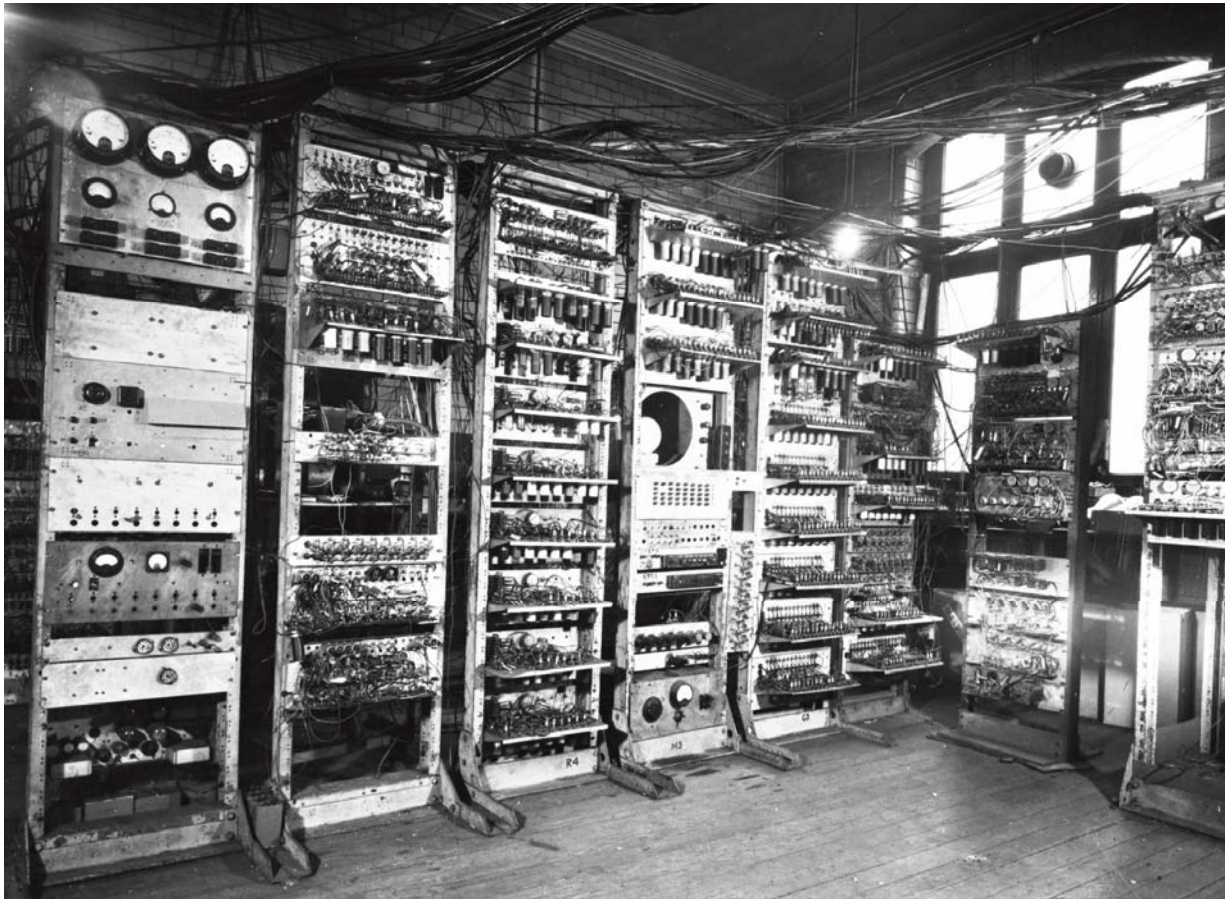

The world's first stored-program computer, running for the first time on June 21, 1948

1958 Integrated Circuit

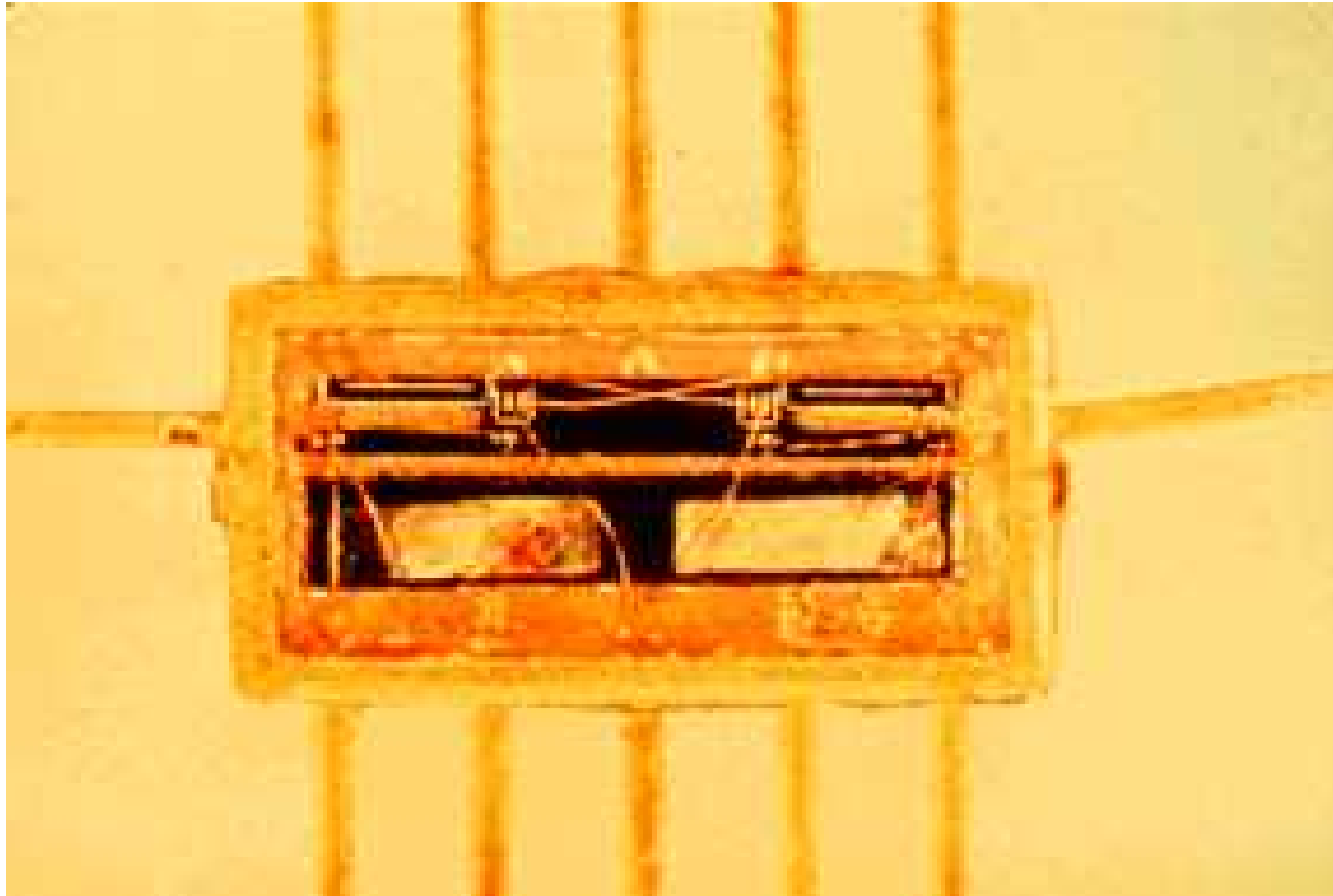

1958: Integrated Circuit

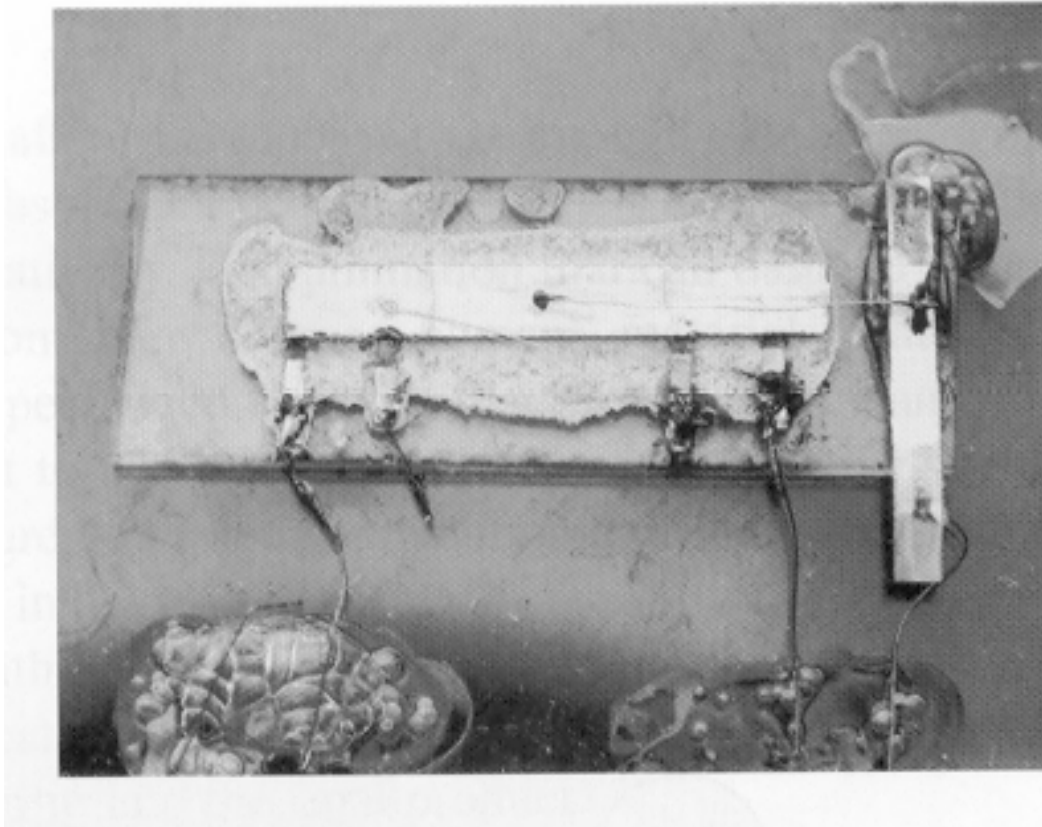

Simultaneously invented by two different people:

- Jack Kilby (TI): required wires
- Robert Noyce (Fairchild): used evaporated aluminum
(with Jean Hoerni, a swiss guy)

1959 Planar Transistor

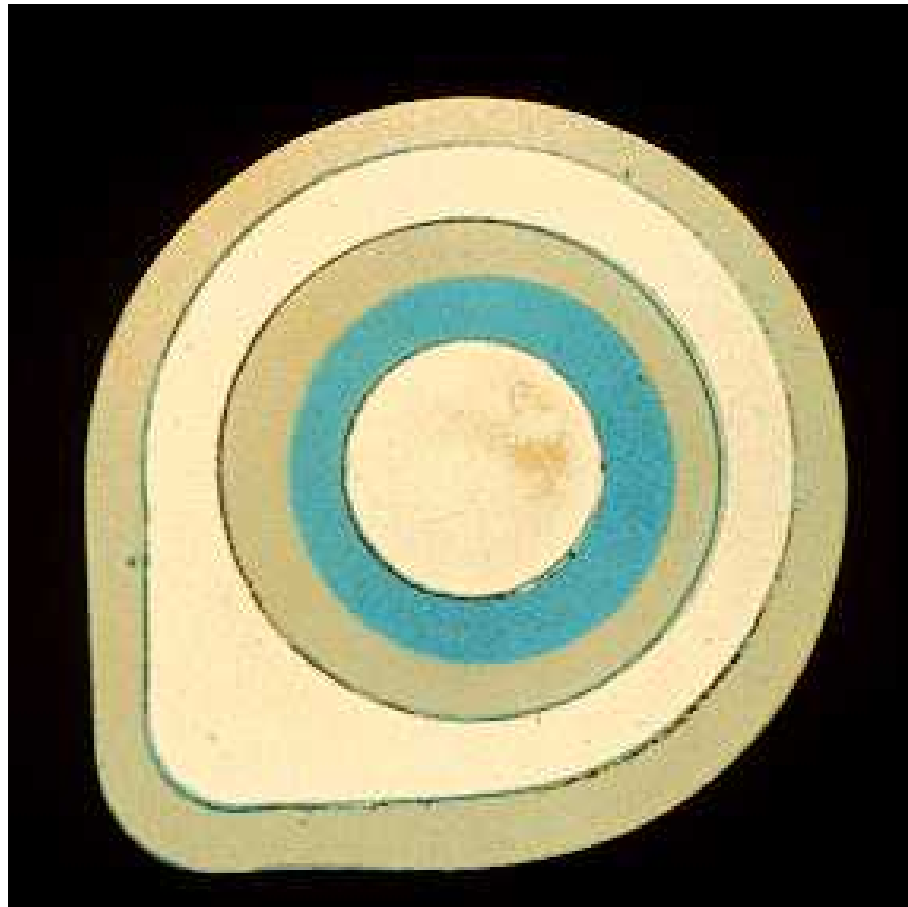

1961 Integrated Circuit

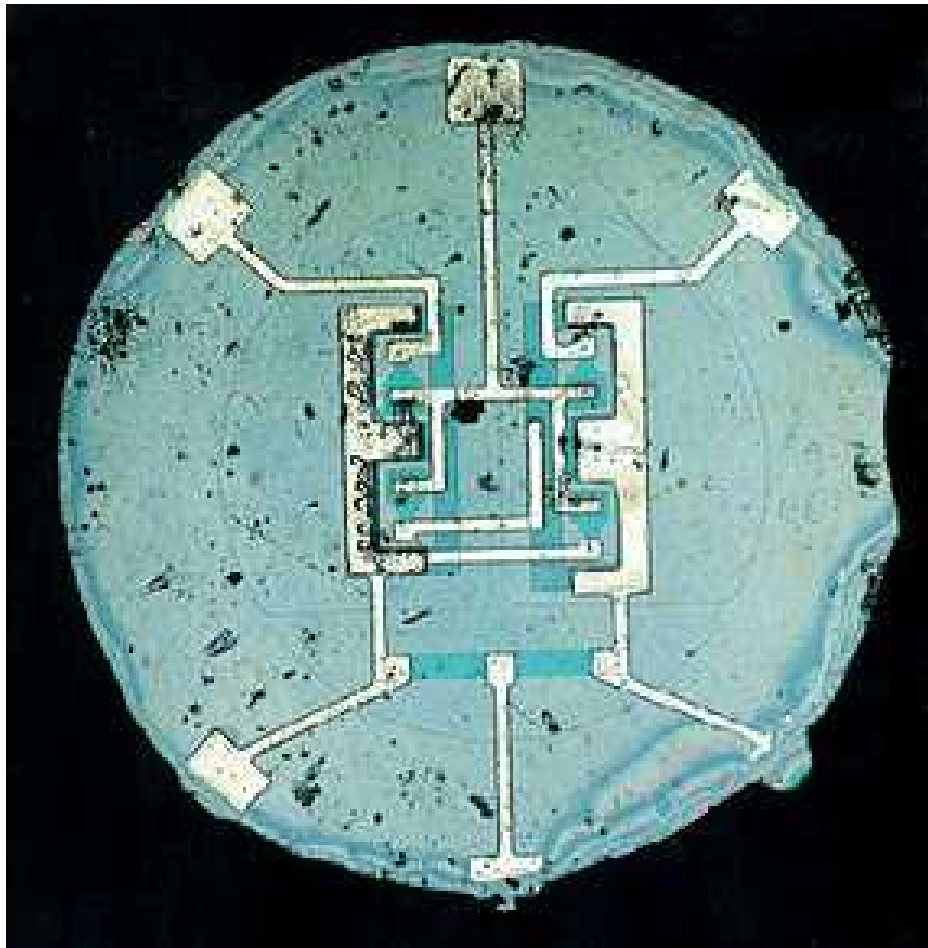

This device, developed by Robert Noyce in the late 1950s, was the first commercially available integrated circuit (it was a Flip-Flop). Courtesy: Fairchild Semiconductor.

1962 NPN Transistor

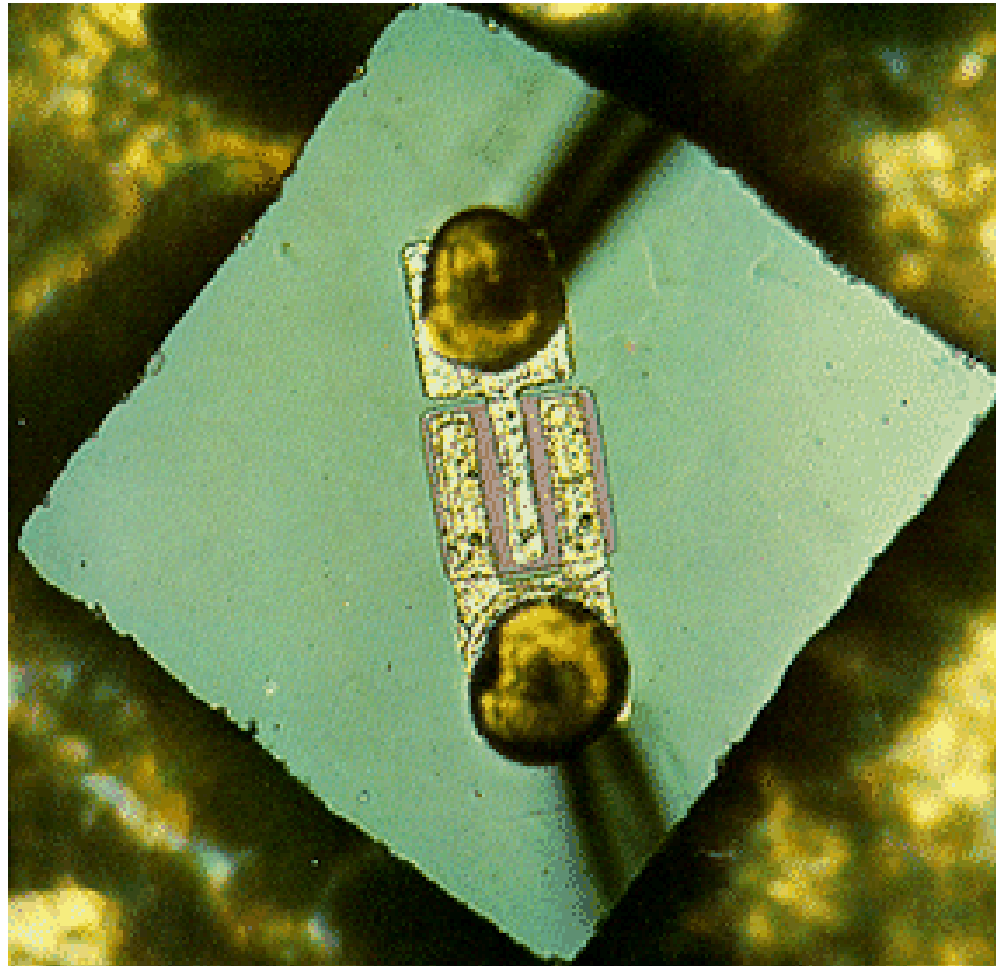

Diodes Logic

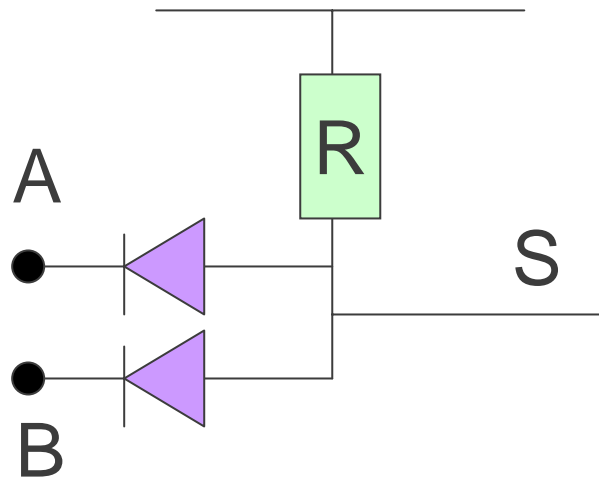

AND Gate:

If either of the inputs is grounded, then that diode is on, and the output S is held low

If S is low, permanent current

1963 RTL Logic

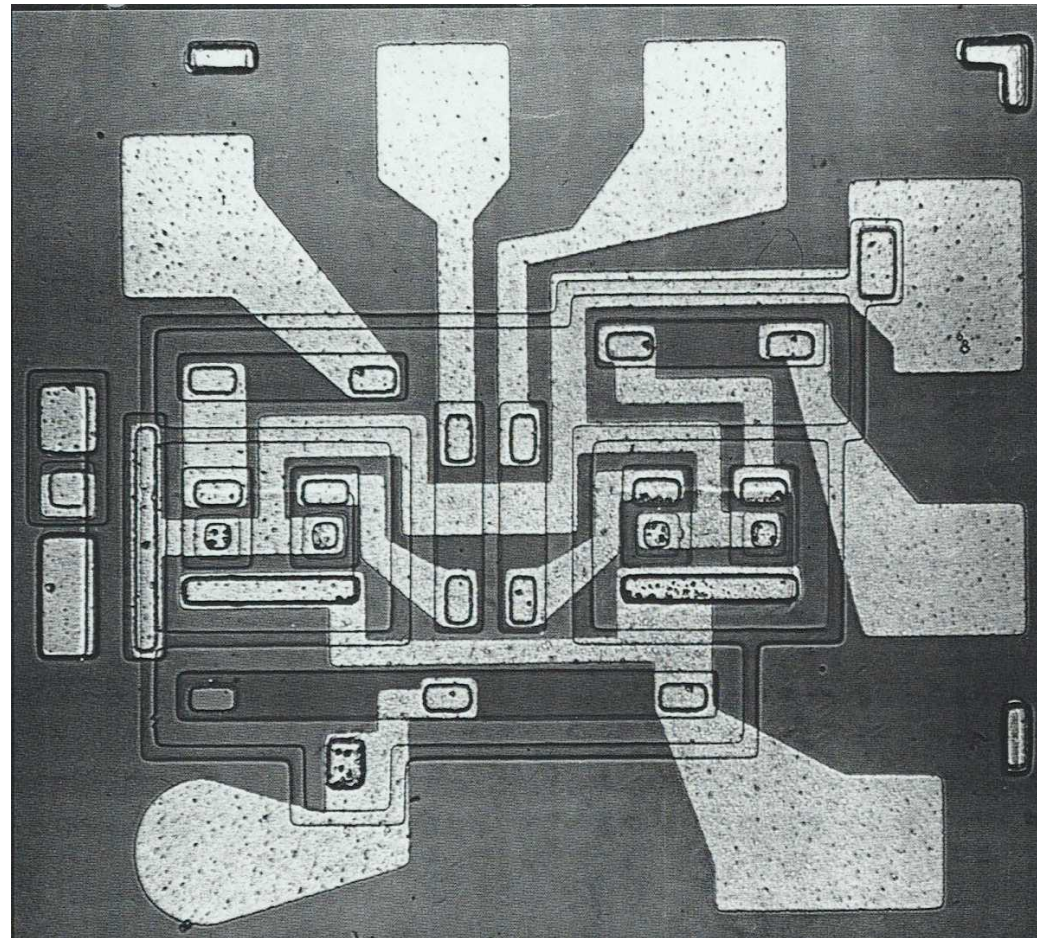

Transistor–Transistor Logic

Now known only as the method used by Neanderthals!

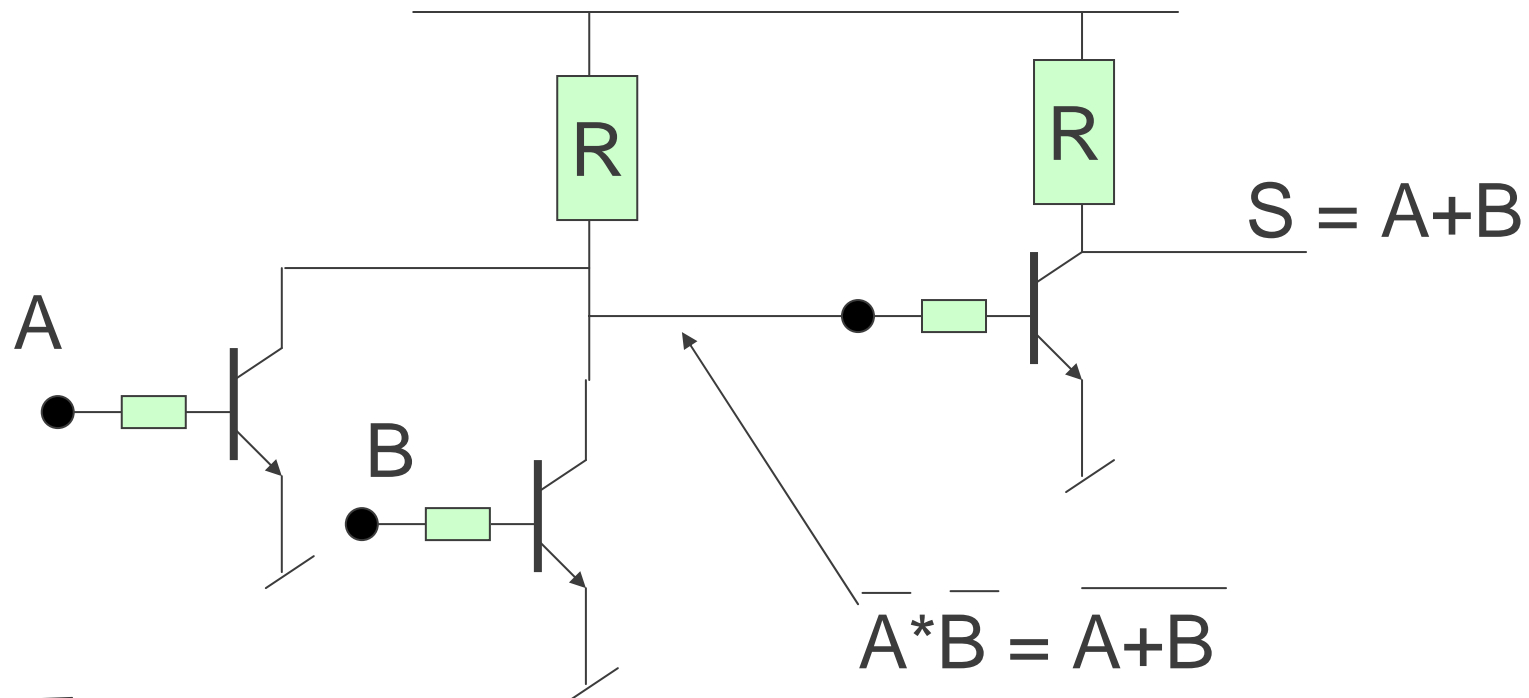

If $\overline{A * B} = 0$, permanent current ! If R about 500 ohm, power is $(5 \text{ V})^2 / 500 \text{ ohm} = 50 \text{ mW}$ per device!

TTL

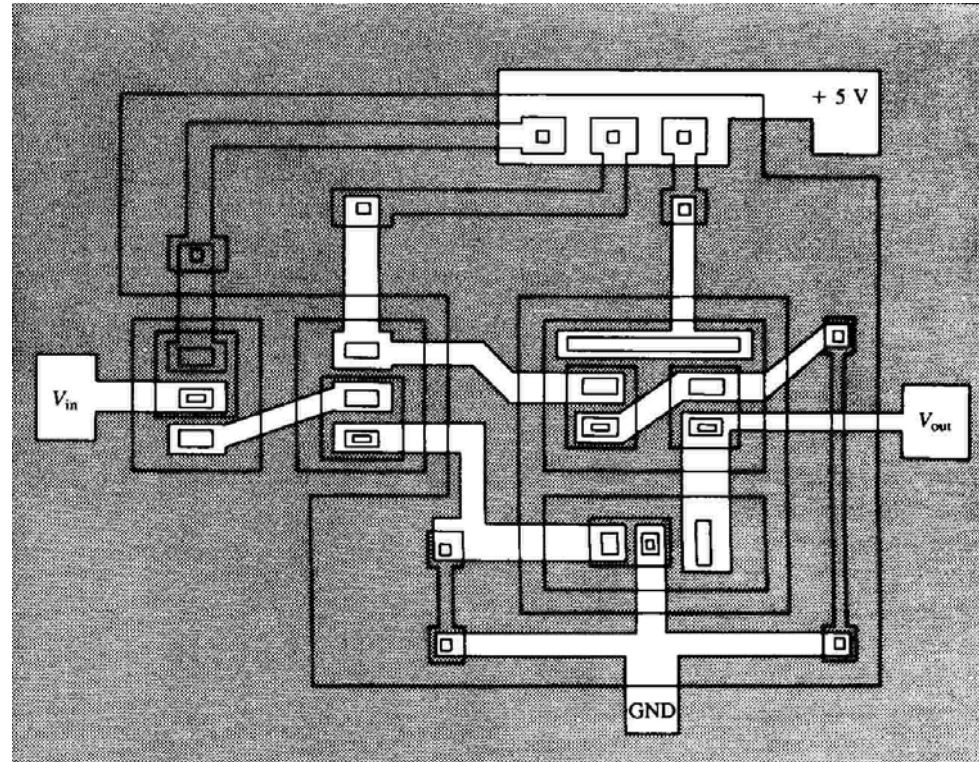
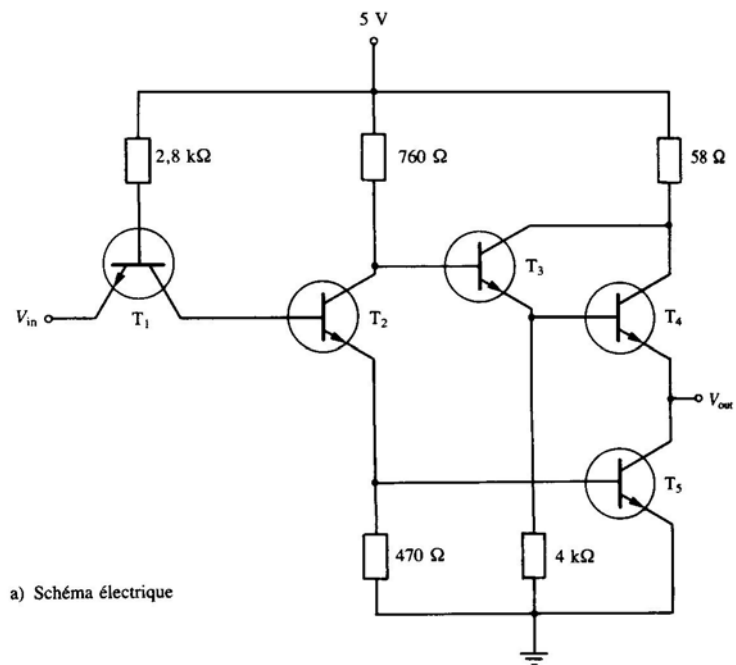

MOS Transistor

- Even before Tszner in France has produced a junction field-effect transistor in 1958, many studies were under way in the U.S. on the possibilities of such a device. In 1959, RCA was working on FETs
- In 1962, RCA was fabricating multipurpose logic block comprising 16 MOS FETs on a single chip
- however extremely sensitive to static charge, supply voltage, oxide effects
- Fairchild abandoned the process, even RCA shifted its emphasis back to bipolar
- In mid-1965, only two companies were producing MOS Ics, ---> P-MOS, N-MOS, CMOS

1967 MOS

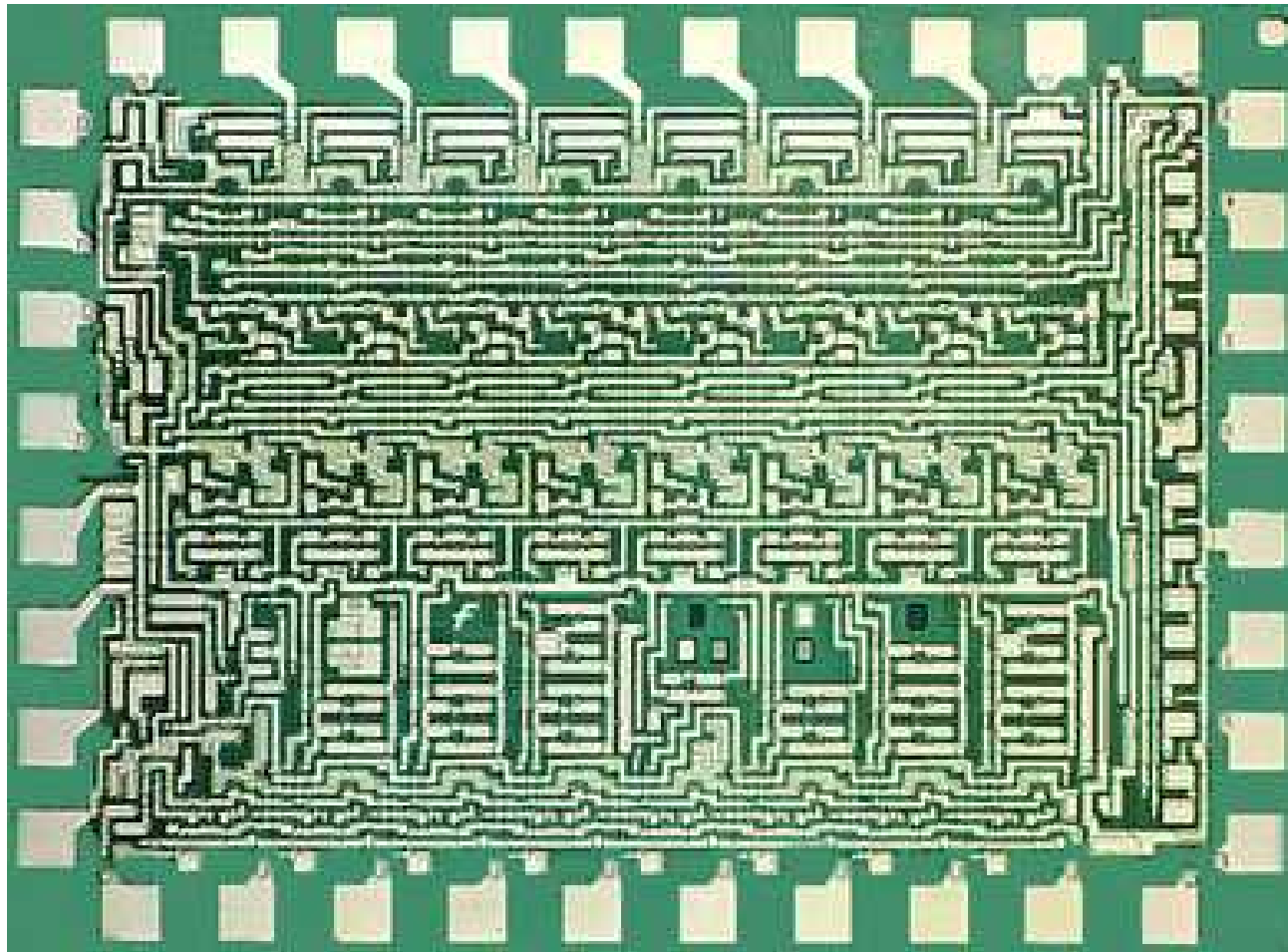

Intel 4004

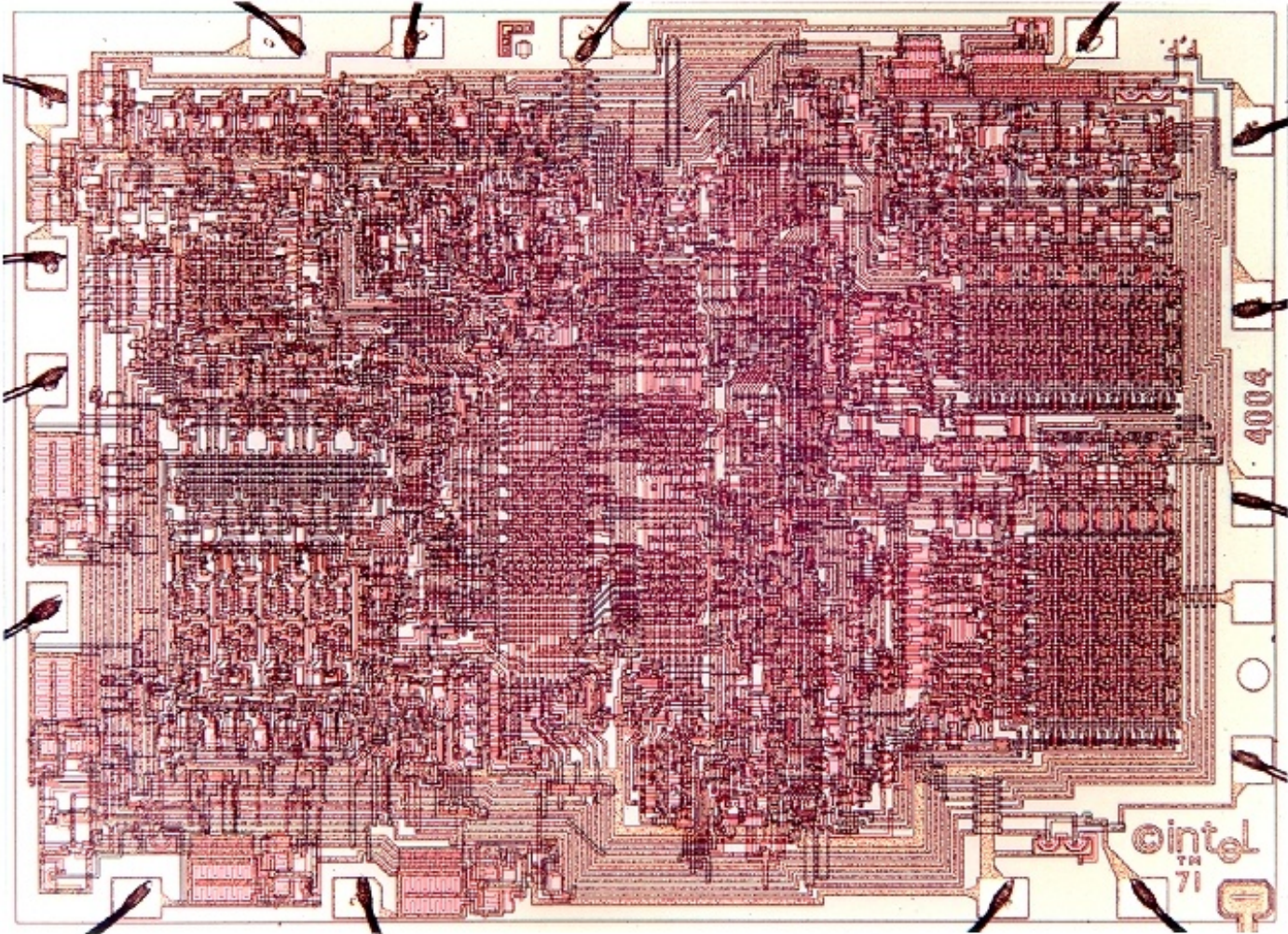

Ted Hoff, Bob Noyce, Gordon Moore

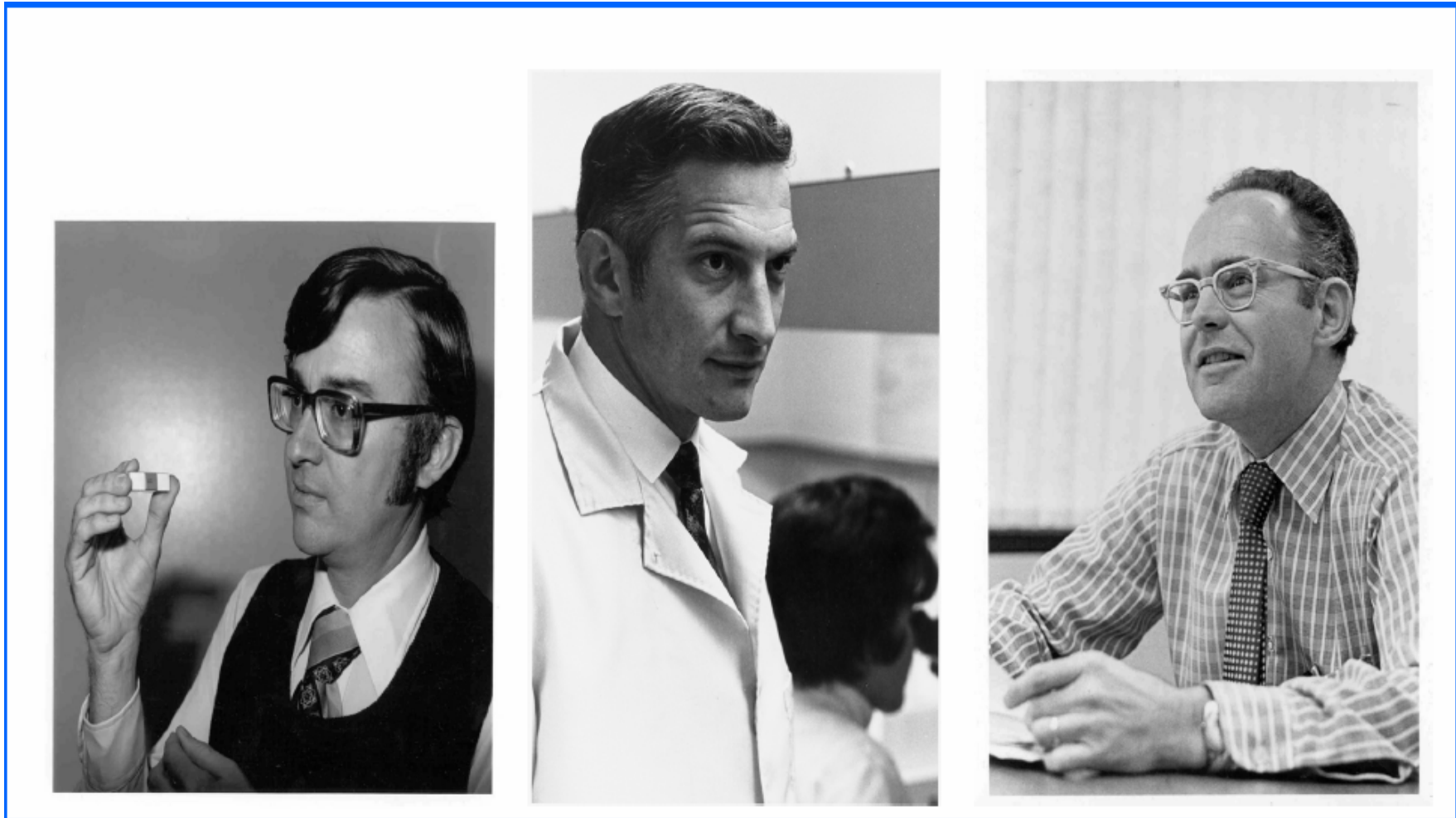

1972 CMOS

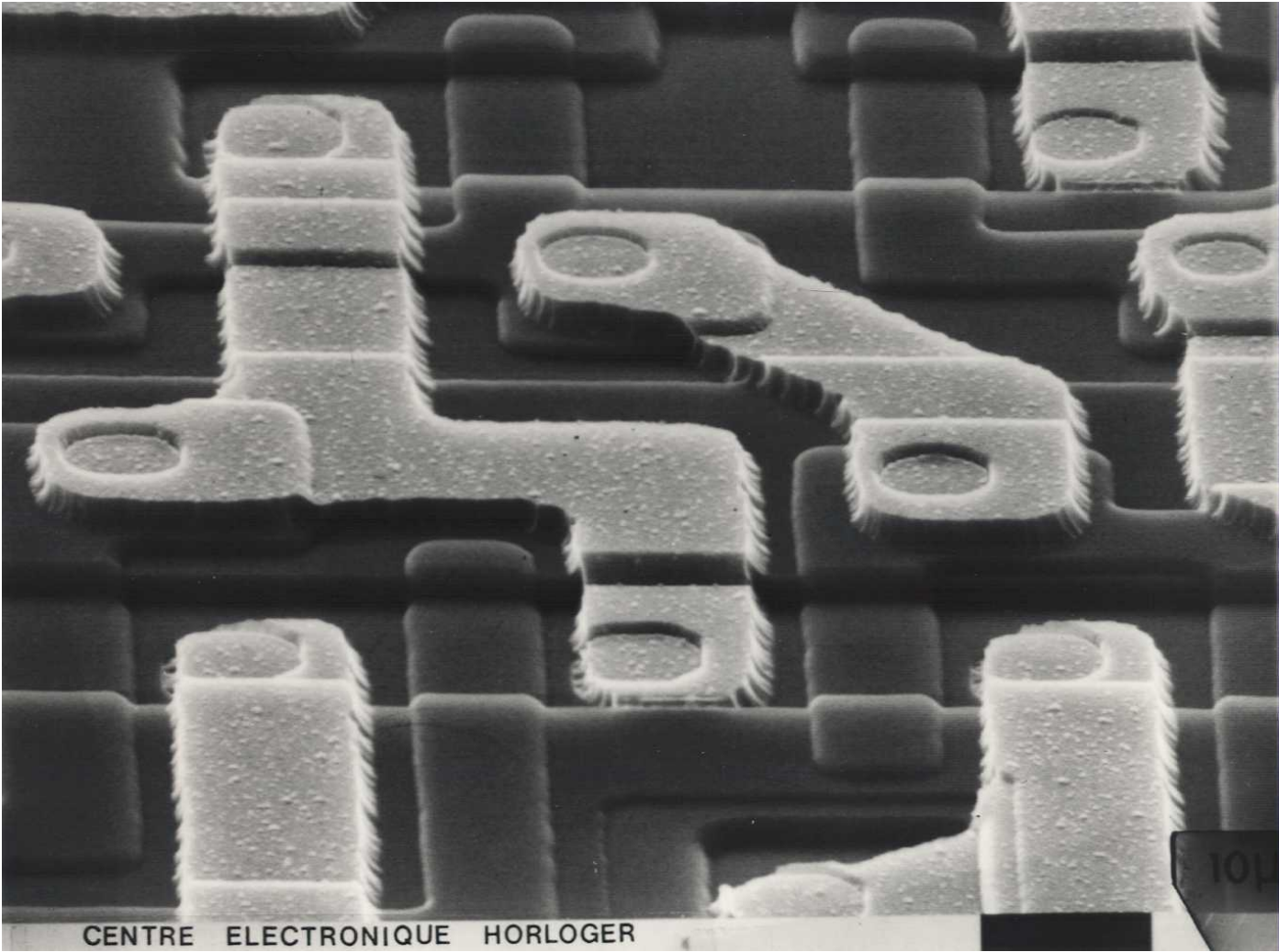

1972 INTEL 8008

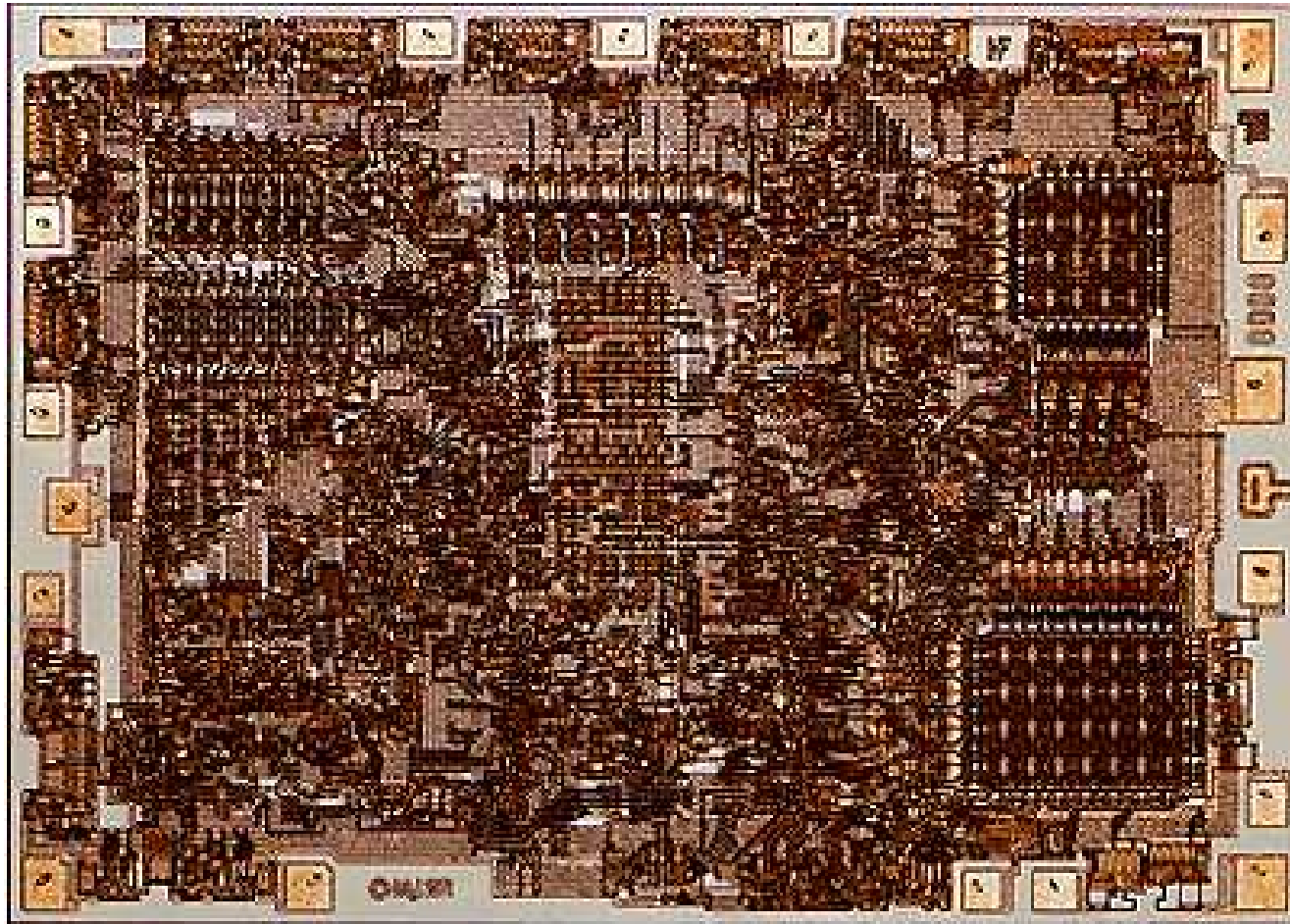

EPROM 4M

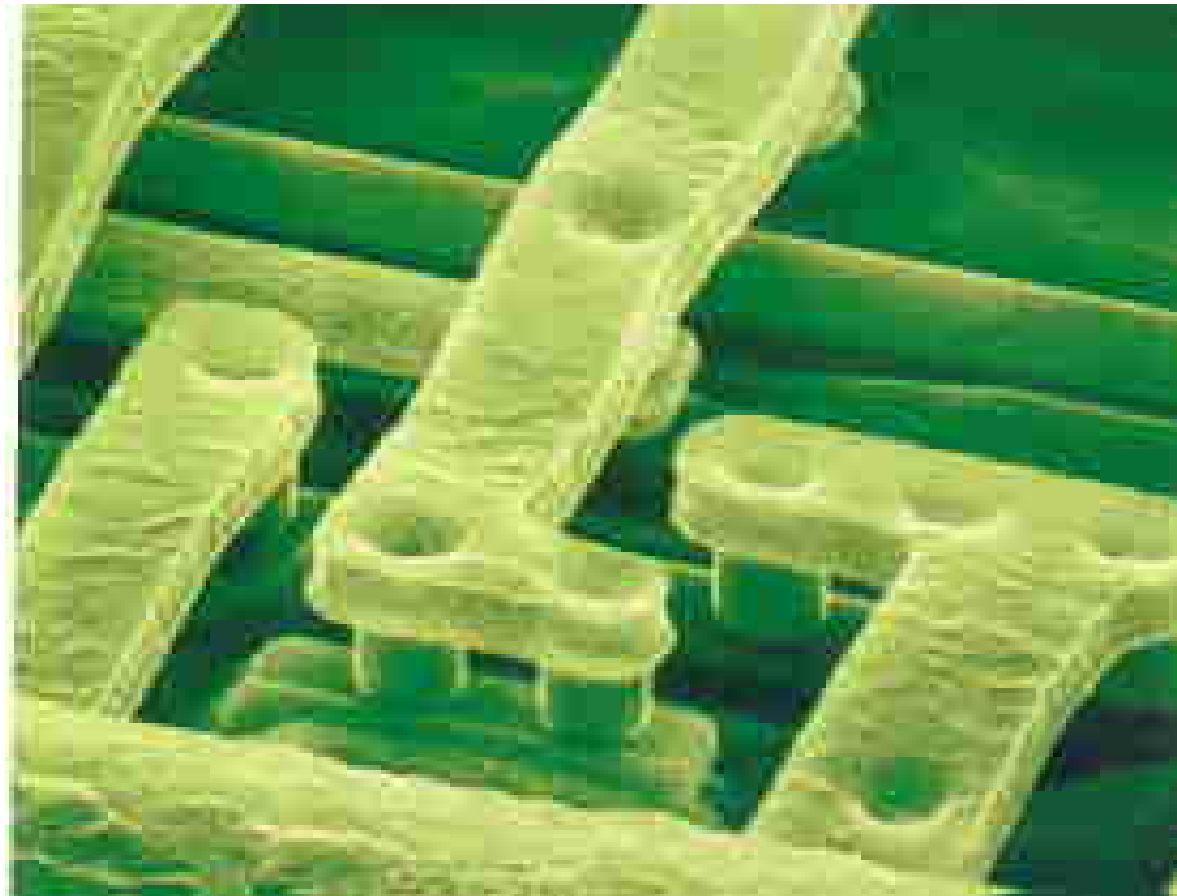

1995 Intel Pentium Pro

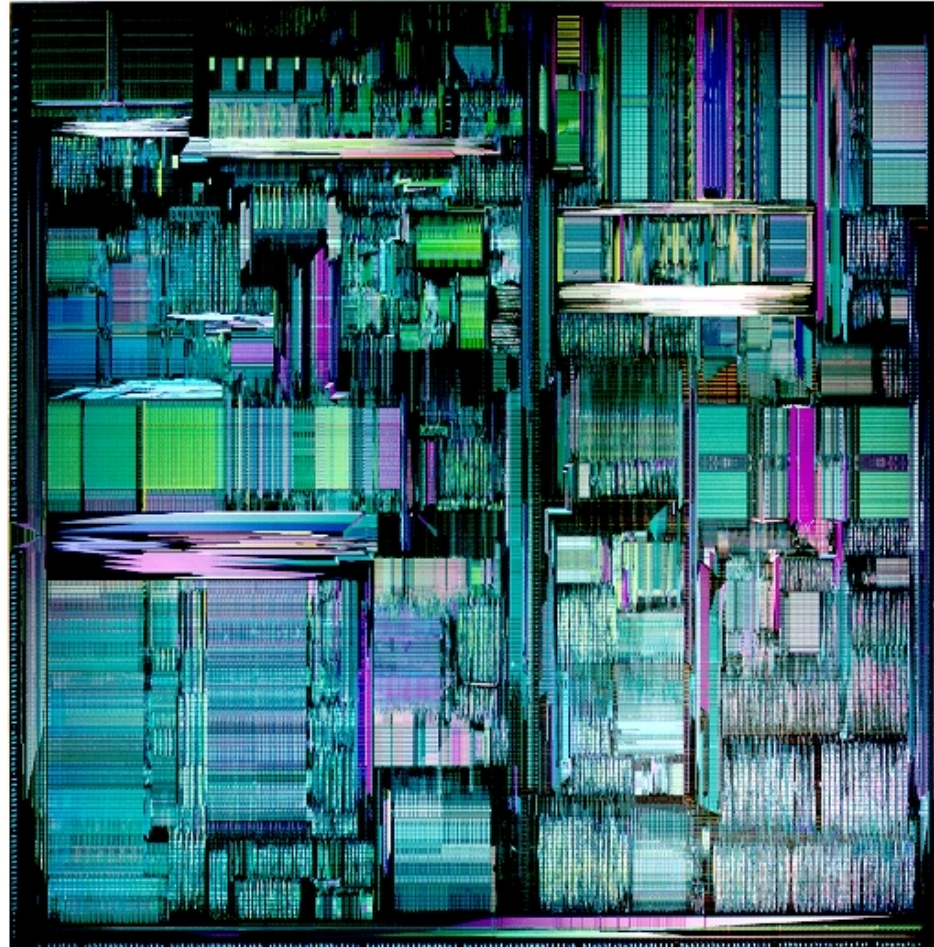

2003: State of the Art MOS (Intel)

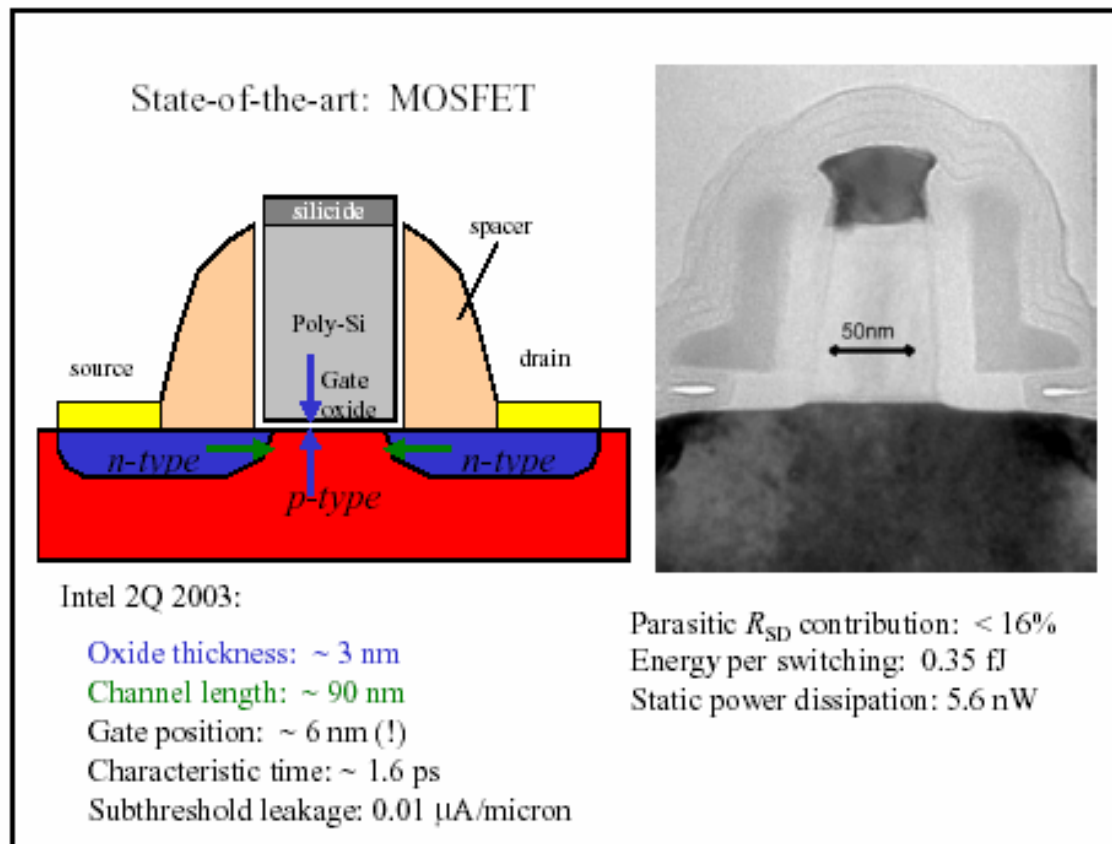

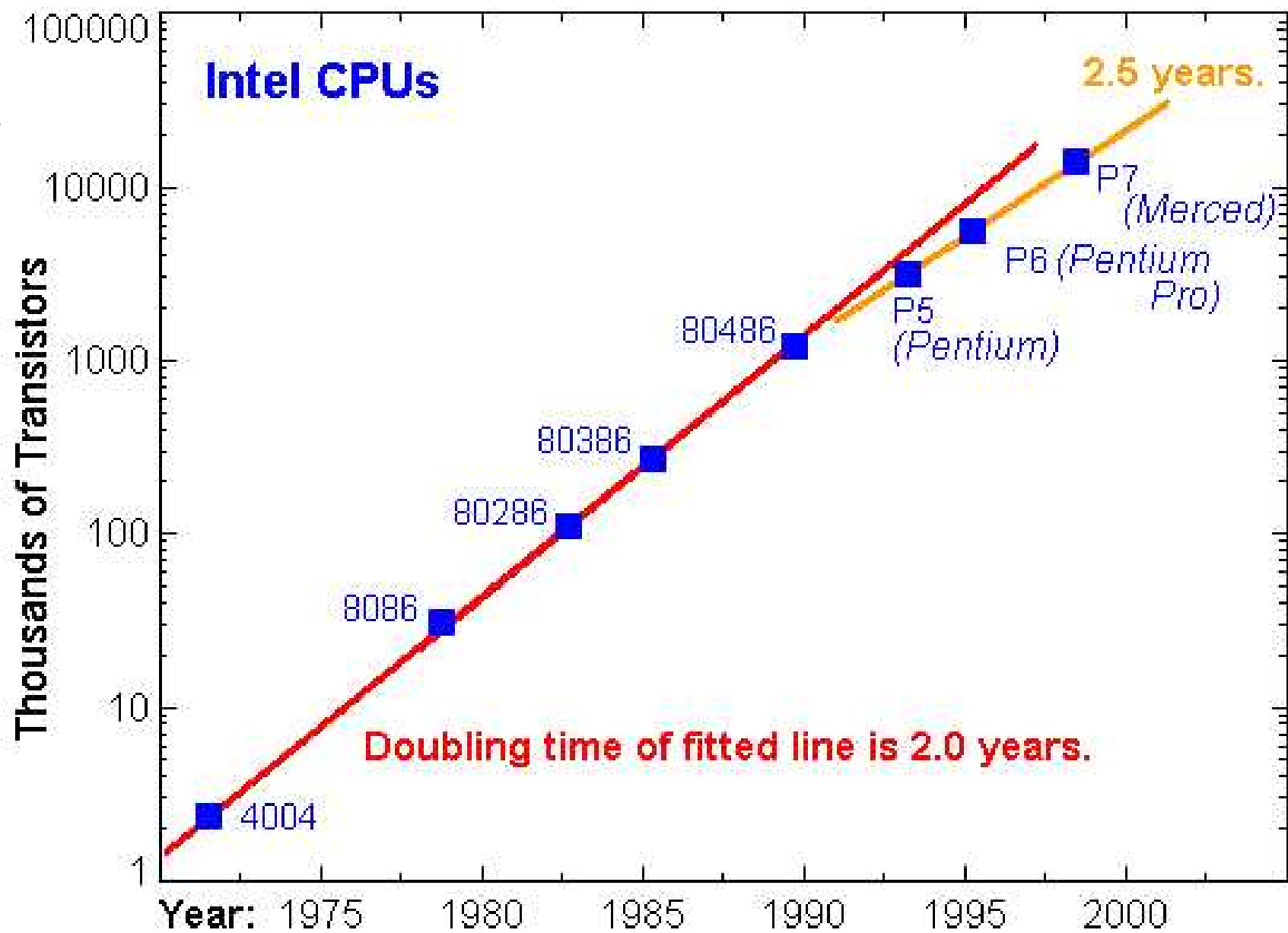

Photo References

- IEEE Spectrum june 1997
- <http://tcm.org/html/history/timeline/threads/components/index.html>
- CEH (presently CSEM), Neuchâtel
- FASELEC (presently Philips) Zürich
- S. Joly, Intelegis Marin
- http://www.intel.com/intel/museum/25anniv/hof/hof_main.htm
- http://infopad.eecs.berkeley.edu/CIC/die_photos/
- <http://micro.magnet.fsu.edu/chipshot.html>

Thank you for your attention.